

Homework 3

Assigned: September 16

Due: September 23

- Trace the execution of Dijkstra's algorithm on the following graph, with vertex *A* as the source vertex. At each step, show the value of the chosen vertex (*w*) and the updates to the distance and parent vectors.

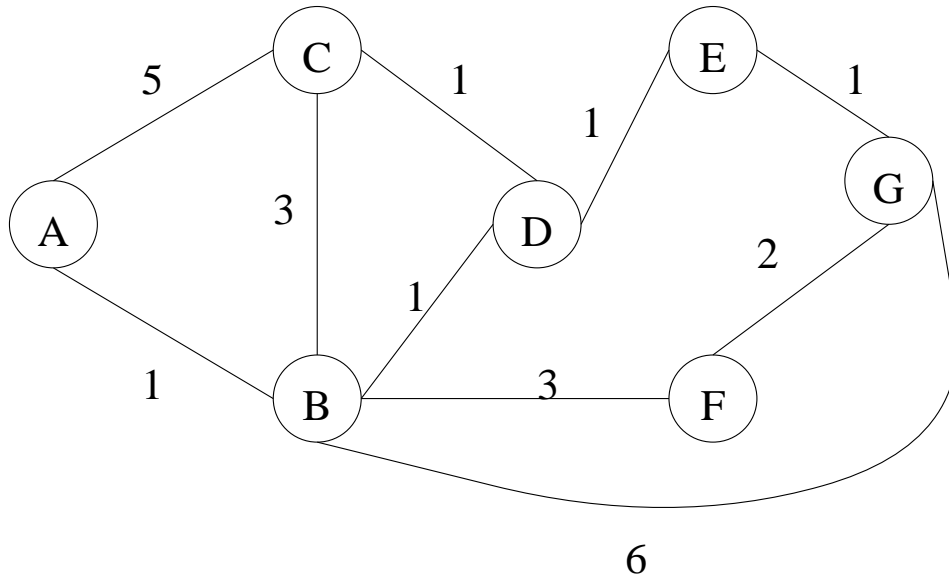

- Give an example of a six node topology in which the distance to one of the nodes is changed the maximum number of times possible during the execution of Dijkstra's algorithm. Show the steps of Dijkstra's algorithm to demonstrate the changes to the distance.
- In class we saw that the distance vector routing algorithm has a problem with slow convergence when a link fails. One solution to this problem is called "split horizon". The idea is that when node *R* forwards traffic for destination *D* through neighbor *N*, then *R* reports to *N* that *R*'s distance to *D* is infinity. Using the example from class, show that this will fix the counting to infinity problem.
- Demonstrate that the split horizon technique does not work if three nodes are involved in a routing loop. Give the topology, state which link goes down, and explain the update messages that will be sent.

5. Let n_i denote the IP address for interface n and n_p denote the physical address for interface n . Consider the following network, containing two Ethernet segments, one router (R) and four hosts (A, B, C, D). The interfaces are all labeled.

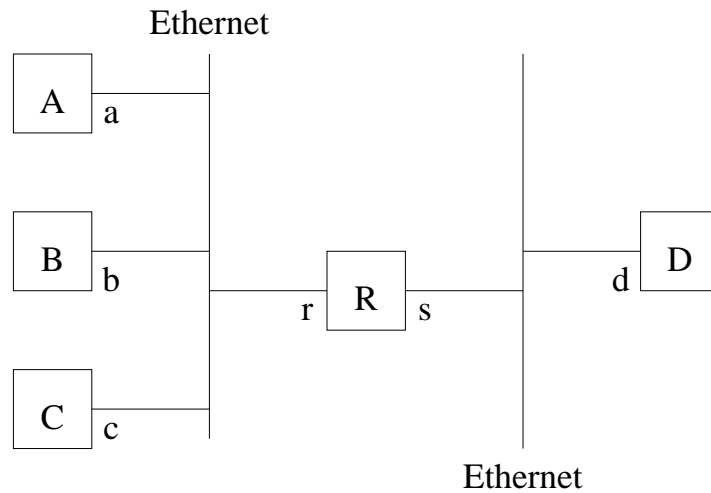

Assume all ARP tables are initially empty. Give the complete contents of the ARP table at host A after each of the following operations:

- A sends an IP packet to B.
- C sends an IP packet to B.
- A sends an IP packet to D.
- A long time later, D sends an IP packet to A.