

Cameras



Irfan Essa
Thursday, Jan 24, 2002
DVFX Spring 2002



Today



- ☐ Cameras / Scenes
- ☐ Intro to MAYA
- ☐ More on Final Projects

Camera / Scenes



- View to the world
- Story-telling
- Movements / Characters / State

Cameras: Lenses



- FOV

- "long" lenses

- "wide-angle" lenses

Cameras: Projections



- Orthographic
- Perspective

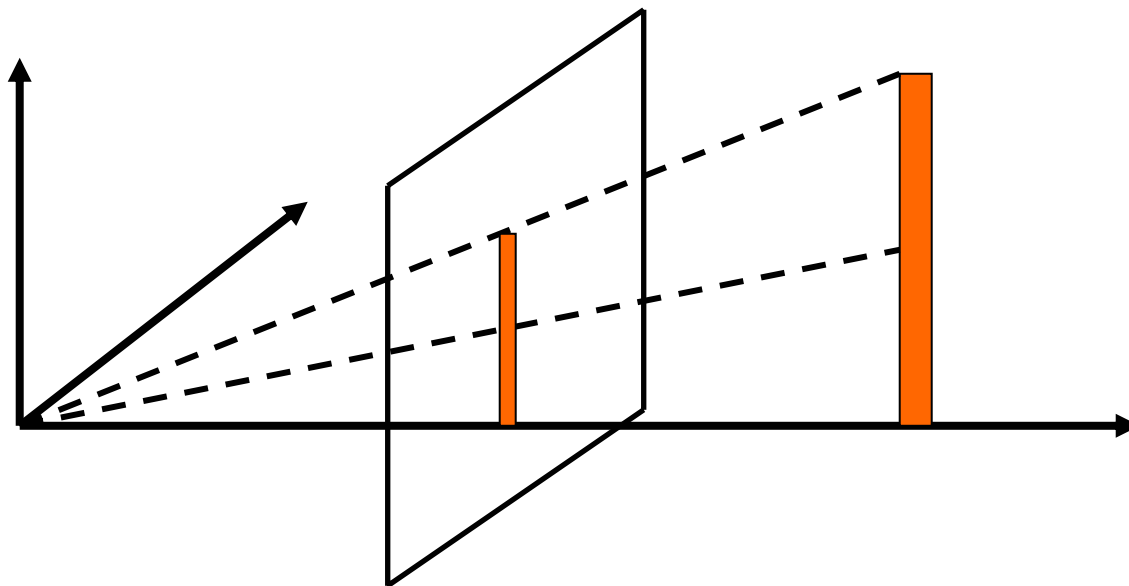

Perspective/Orthographic

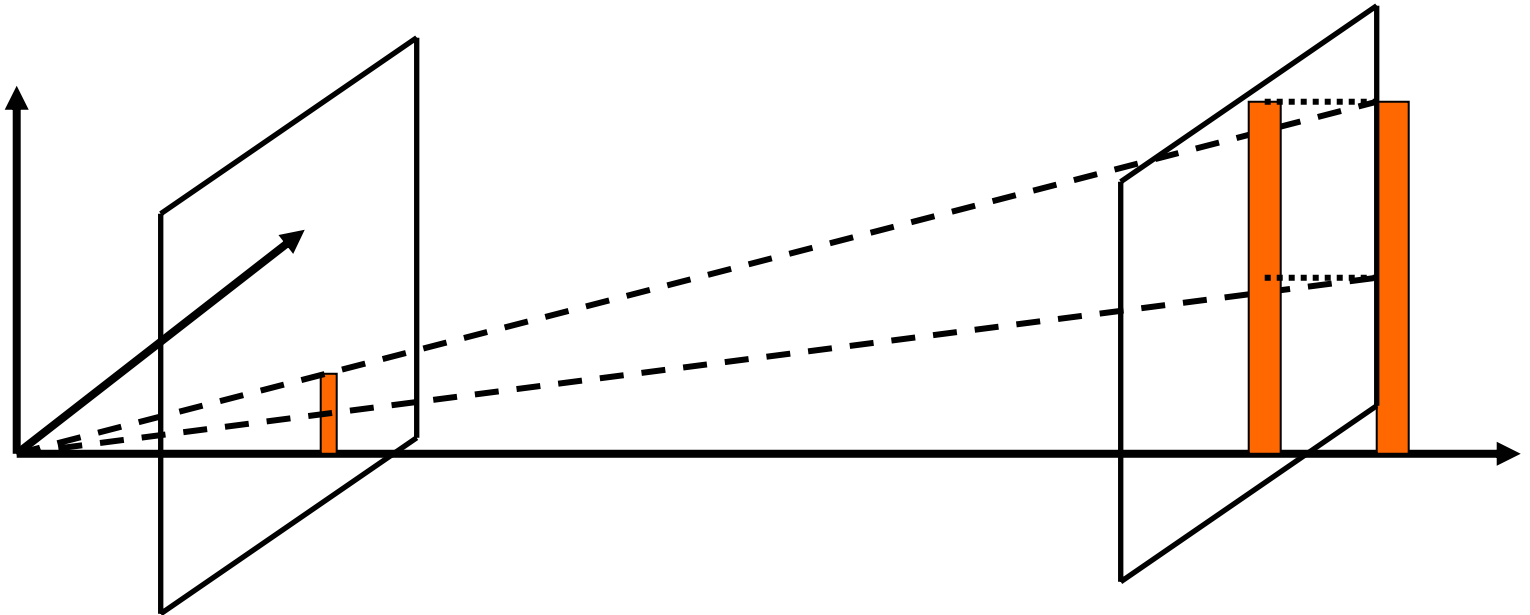

Perspective

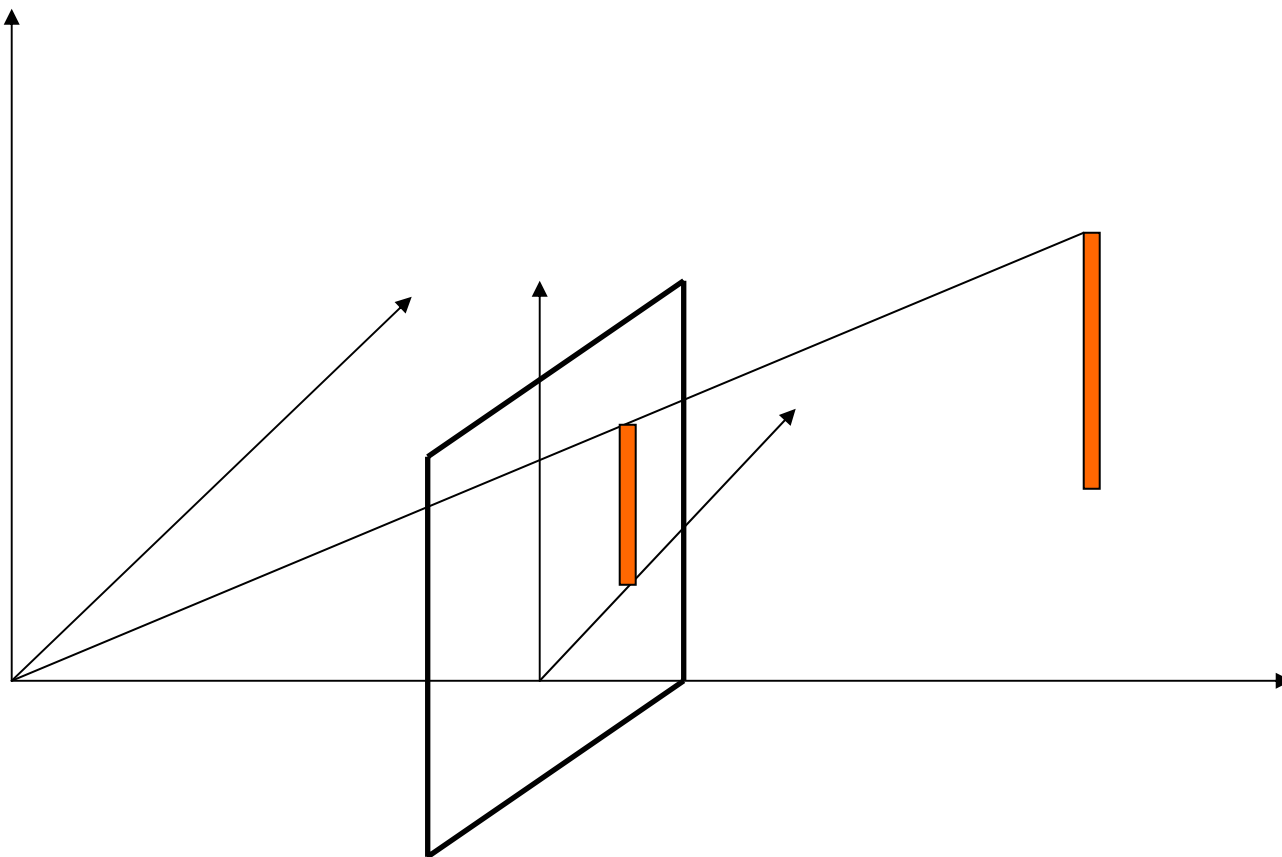

Cameras



Height

Angle

Roll

DOF

Camera Motion



Pan

Tilt

Zoom

Dolly