

Overview of IXP2400 Architecture

- Intel 2nd generation network processor
- designed for network processing
 - goal to optimize for *fast path*, and accommodate *slow path*
 - programmable – fast deployment of new services, upgrades, protocols...
 - needs external control processor

IXP2400 chip highlights

- 8 microEngines (uE)
 - RISC 600MHz processors with instruction sets targeting networking-related operations
 - for fast path
- XScale core
 - standard embedded CPU (ARM family) running Linux
 - slow path
- Media and Switch Fabric (MSF) Interface
 - to Rx/Tx packets from physical layer and/or switch fabric, i.e. main data path interface
 - separate 32b Rx and Tx busses @ up to 125MHz w/ 8kB buffers
 - various configs up to 4Gbps (ours 3x1GbEthernet)
 - connects to external devices and is configurable for different bus protocols

- DRAM controller
 - for packet storage (up to 2GB, but access slow ~300 cycles, 64bit wide)
- SRAM controller
 - store packet queues, lookup tables..., ~150 cycles, 32bit)
- Scratchpad memory (16k)
 - on chip, for parameters, communication b/w uEs...
- PCI bus (64bit/66MHz)
 - connect to “host” – external control processor, or other PCI-compliant devices (e.g. chain IXPs together)
- Other units
 - Hash, control registers, other peripherals (timers, interrupt controller...), perf. monitors...

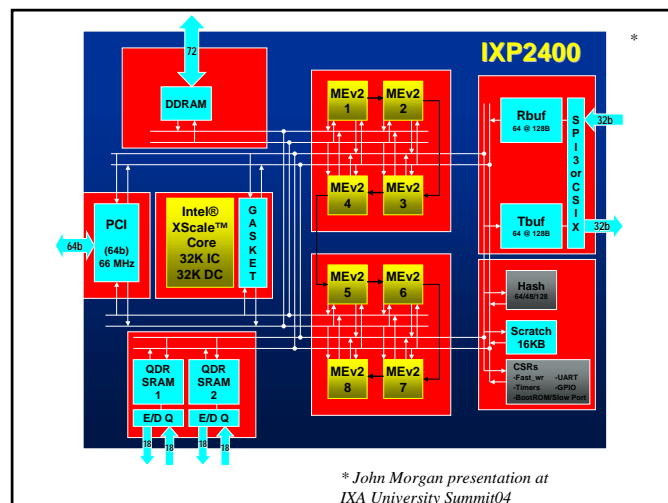

Microengine MEv2

- control store
 - for instructions... 4k 40bit instruction **per** uE
- 8 hardware supported threads
 - hide memory access
 - separate register sets (PC) – fast ctx switch
- registers
 - 256 GPR (32/thd), 512 Xfer (4x16/thd – [D|S]x[R|W]), 128 NN (16/thd)
 - addressing context relative or absolute (GPRs)
 - local memory 640x32bits
- CAM – 16 entry cache

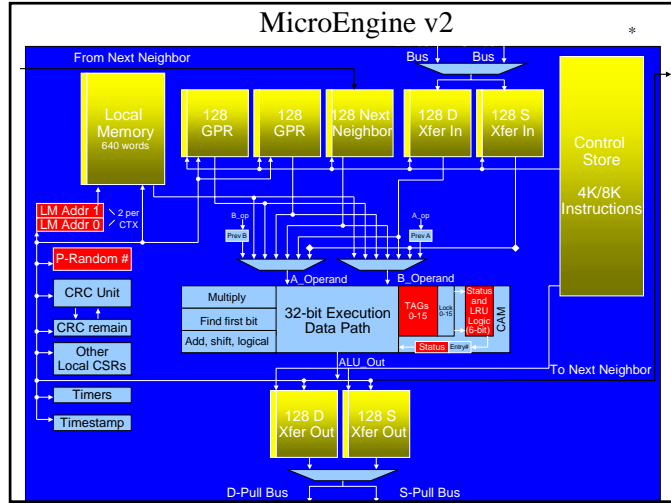

IPC

- messaging via circular queues (rings)
 - scratch/SRAM operations for ring management
- signaling
 - 15 signals per context
 - context can poll a signal explicitly
 - use to guard critical sections

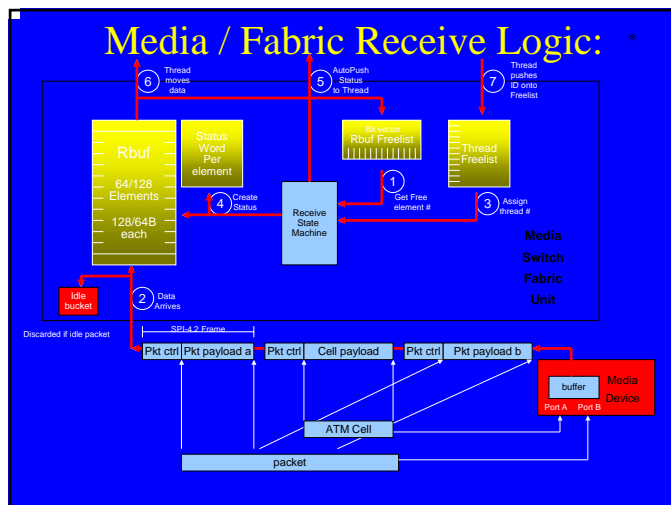

ILAB setup

www.cercs.gatech.edu/projects/npg/ilab/



hardware manual:

[/net/hp31/ixpdev/sdk3 or 4.0/Docs/IXP2400/](#)

software tools:

[.../Tools/...](#)

our IXP2400 Boards:

Radisys ENP-2611

[/net/hp31/ixpdev/CD-Images/](#)

[IXA_Education_Wktn3.1/Docs...](#)